

# INGROUND COVER INSTALLATION GUIDE

## GENERAL INSTRUCTIONS

**Step 1:** Refer to Anchor Plan provided with cover. Cover must be laid out according to the plan to ensure proper installation.

**IMPORTANT:** DO NOT DRAG COVER

**Step 2:** Using stakes and a rope, lay a rope grid across the pool as shown in figure 1. Rope must be tight enough to support the cover while you install it.

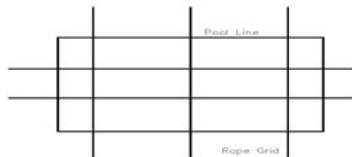
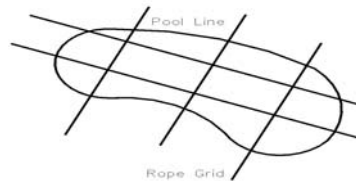

Figure 1:



**Step 3:** Stretch cover across pool, align to raised obstructions and/or cutouts and adjust for equal overlap on all sides. Overlap may vary 2" - 4" from approximate overlap given depending on cover size and shape. **Please note overlap on commercial covers may vary 6" or more.**

**Step 4:** Locate anchor positions on Anchor Plan for straps numbered 1-4 (see figure 2). Measure and mark anchor positions on deck 20" from edge of cover (22" for commercial covers). **NOTE:** Rectangle corners should be installed last.

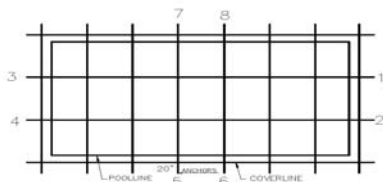
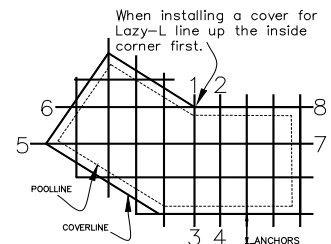
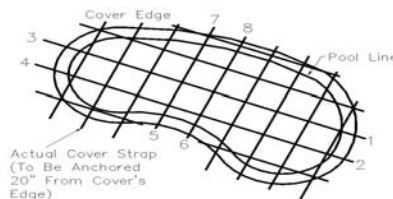

Figure 2:



**Step 5:** Install anchors (see page 2) and attach springs (see page 3) for straps numbered 1-4 in the order shown in figure 2. To ensure proper fit, follow spring compression guidelines on page 3.

**Step 6:** Locate and Install anchors and springs for straps numbered 5-8 in the order shown in Figure 2

### RECTANGLE:

#### **Step 7:**

With first 8 anchors secured, snap a chalk line along the perimeter of the pool using installed anchors as a guide. Chalk line should be parallel to pool, this will ensure that all anchors will be aligned.

#### **Step 8:**

Install remaining anchors working from the middle of the pool out, pulling back each strap until cover edge is aligned. Chalk line should indicate proper distance for anchors, (approximately 20" standard or 22" for Commercial covers)

#### **Step 9:**

When all anchors and springs are installed, conduct a final check. Adjust all springs so that tension is equal on all parts of the cover and the cover lies flat on deck in a straight line on all sides.

### FORMFIT:

#### **Step 7:**

With first 8 anchors secured, locate and install remaining anchors in an alternating pattern, working from the middle of the cover to the ends. Secure each spring as individual anchors are installed.

#### **Step 8:**

When all anchors and springs are installed conduct a final check. Adjust all springs so that tension is equal on all parts of the cover and the cover lies flat on deck, with no bunches or creases.

### IMPORTANT:

Required water levels listed below **MUST** be maintained:

Loop-Loc MESH Safety Cover	15-18" below top of pool
Loop-Loc SOLID Safety Cover	12-16" below top of pool

### IMPORTANT

**WATER LEVEL:** In snow areas, water level must be maintained high enough to support the cover and prevent excess wear. Emphasize to customers that they must not allow the water level to fall below the above recommendations throughout the winter, or **their warranty will be void.**

# Anchor Installation

## Installing Anchors In Concrete Decks

Once anchor positions have been determined (see General Instructions, page 1) you will need to drill holes in the concrete deck at these points to accommodate LOOP-LOC's brass anchoring system.

### Step 1:

Drill  $\frac{3}{4}$ " hole at anchor point  $2\frac{1}{4}$ " deep. For best results, it is recommended that a rotary hammer drill and a long spline bit be used. To maintain consistent depth in all the holes, use tape to mark a point  $2\frac{1}{4}$ " from the tip of the bit, and drill to this point each time.

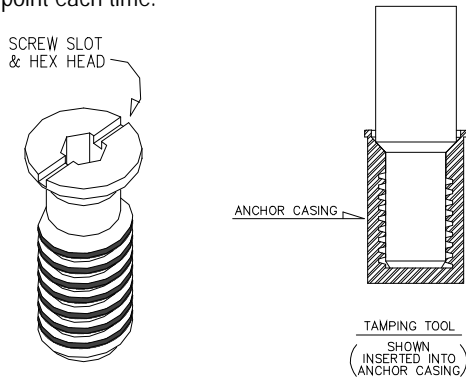

Figure 3:

BRASS SCREW INSERT

### Step 2:

**IMPORTANT:** Use silicone spray on all anchor inserts, shells and Tamp Tool before installing. When cover is removed, all anchors must be flushed out with a hose and re-sprayed with silicone before closing. If this is not done, you may encounter difficulty when trying to raise inserts in the fall.

### Step 3:

Insert brass anchor casing into hole and tamp lightly with Tamp Tool to ensure tight fit, as shown in Figure 4.

### Step 4:

Screw brass insert into casing, as shown in Figure 4.

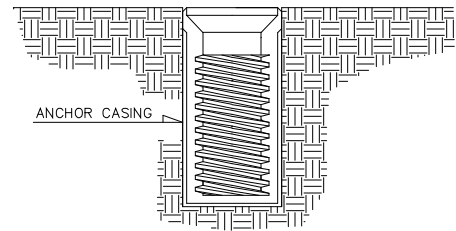

Figure 4:

## Installing Anchors In Other Surfaces

**PAVERS, BRICK OR STONE:** When decks are made with brick, stone or pavers laid on sand, or on a cement slab, the anchor-in-pipe method must be used or the cover cannot be considered safe and warranted.

For each anchor to be installed by this method, you will need to use  $\frac{3}{4}$ " inside diameter pipe or conduit. Pipe comes in 9", 15" & 18" lengths.

### Step 1:

Using rotary drill with 1" bit, if using pipe supplied by LOOP-LOC, or appropriate sized bit for pipe you are using, drill hole through the deck large enough to accommodate pipe or conduit at anchor points. Wherever possible, drill between bricks or pavers to avoid cracking them. Continue drilling in case concrete is laid under the soil.

### Step 2:

Drive assembled pipe through hole into ground until flush, as shown in Figure 5. Place a block of wood or other material over the end of the pipe before driving to prevent damage to the anchor assembly.

### Step 3:

Screw brass insert into casing, as shown in Figure 5.

**GRAVEL, SOIL, OR PLANTER AREAS:** When anchors are to be installed directly in any type of gravel, soil or loose ground, you must also use the anchor-in-pipe method. If more than 35% anchor-in-pipe installation, in a loose unstable area, the pipe should be set in concrete footings.

**WOOD DECK:** If a wood deck is at least 1 5/8" thick, the standard concrete deck anchoring procedure may be used. If deck is thinner, we recommend an anchor-in-pipe installation method. Wood Deck Anchor Flanges may also be used, **at the dealer's discretion**, depending upon the quality, thickness and strength of the specific type of wood at the job site.

**Note:** Any synthetic wood type materials that do not meet the above criteria should utilize the standard anchor in pipe method.

**Anchor-In-Pipe:** Follow the instructions for PAVERS, BRICK OR STONE. **IMPORTANT:** You must use pipe or conduit long enough to extend into the ground itself, taking into account space between wood deck and ground (see Figure 6). Pipe must always be inserted into ground for cover to be considered safe and warranted.

**Wood Deck Anchor Flanges** are installed as follows (see Figure 7):

### Step 1:

Counter-sink  $1\frac{1}{2}$ " diameter hole  $1/8$ " deep into wood deck using self-boring bit.

### Step 2:

Drill  $\frac{3}{4}$ " diameter hole into wood deck - minimum 2" deep.

### Step 3:

Insert wood deck anchor flange into hole and tap until top of flange is flush with wood deck.

### Step 4:

Secure flange with 4 wood screws.

### Step 5:

Screw brass insert into flange, as usual.

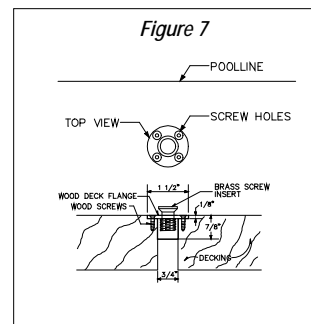
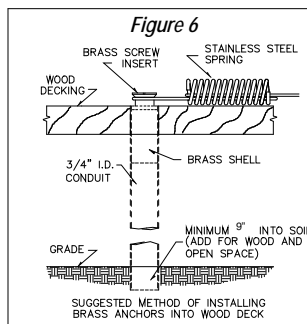
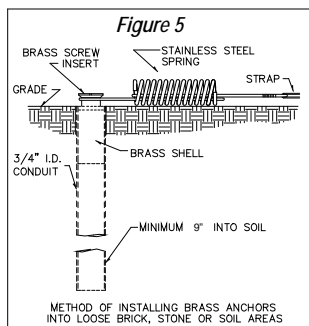

# Spring Installation

## Attaching Springs To Straps

Lace straps around the squared-off end of springs using the method pictured in Figure 8. This allows for easy adjustment of straps, thus ensuring proper compression of springs.

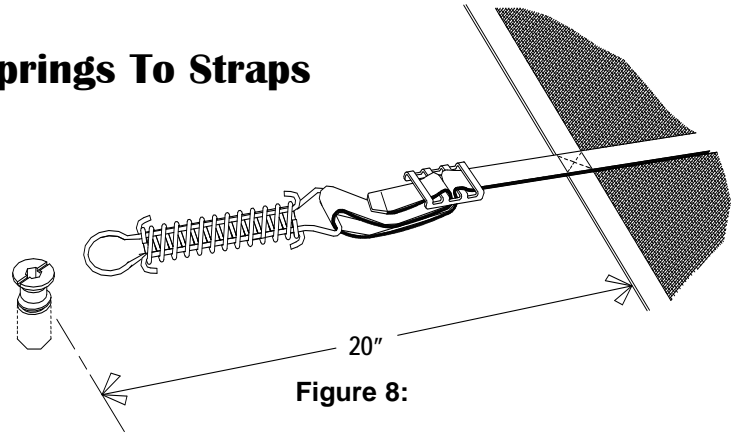

## Installing Springs On Anchors

### Step 1:

Insert Installation Rod through retaining ring on end of spring (see Figure 9).

### Step 2:

Place heel of rod behind anchor bolt. Pull rod handle away from cover edge, until retaining ring on spring slides over anchor bolt (see Figure 10).

### Step 3:

Rotate rod until heel is free from anchor bolt. Cover is now secured to anchor.

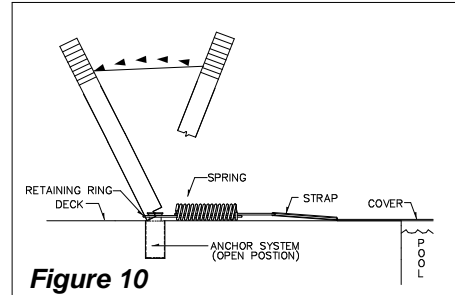
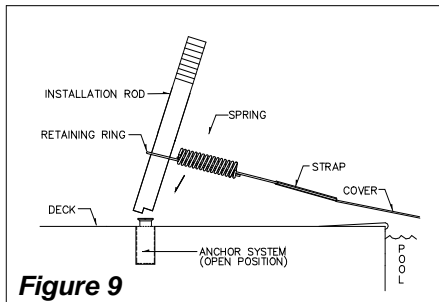

### BEFORE LEAVING INSTALLATION SITE:

Proper spring compression is crucial for a correct fit in all installations. Spring tension adjustment is accomplished by shortening the strap length between the frame of the cover and the spring assembly via the stainless steel buckle. The spring must be removed from the anchor in order to do so. Please adhere to the following compression instructions:

**LOOP-LOC Super Dense & Aqua-Xtreme Mesh Safety Swimming Pool Covers (In-Ground):** New mesh covers tend to shrink in their cartons. By compressing springs almost totally (at least 85-90%) during the initial installation, you will ensure that the cover will stretch back to its normal size. It is also recommended that the springs be retightened 2 to 3 weeks after initial installation to ensure that they remain approximately 70-75% compressed at all times. Initial compression of 85-90% results in a coil length of 2 1/4" and maintained compression of 70-75% results in a coil length of 2 1/2". The water level in your In-Ground pool should be maintained between 15" to 18" below coping level and 14" below coping level for On-Ground pools.

**ULTRA-LOC SOLID Swimming Pool Covers (In-Ground):** Due to the very minimal stretch of Ultra-Loc material, initial spring compression for our Ultra-Loc covers should be set to approximately 60%. 60% compression results in a coil length of 2 3/4". Tension adjustments may be necessary to promote proper drainage. When equipped with drain panels, spring tension adjustments may be necessary to promote proper drainage. Before leaving jobsite, run a garden hose over the entire cover for at least 5 minutes, simulating a heavy rainfall. If water accumulates, adjust the springs tension until the water drains completely. To maintain safety, any standing water must be pumped off immediately and water levels should be maintained between 12" - 16" below coping level for In-Ground pools and 12" - 14" below coping level for On-Ground pools. An approved automatic cover pump is available from Loop-Loc.

Only when the above steps are followed, has a correct and complete installation occurred!

## Removing Springs From Anchors

### Step 1:

Insert Installation Rod over anchor bolt with heel of rod facing cover (see Figure 11).

### Step 2:

Pressing downward, rotate rod 180 degrees so that heel of rod is between anchor bolt and retaining ring (see Figure 12).

### Step 3:

Tilt rod slightly toward cover until retaining ring slides off anchor bolt. Cover is now released from anchor.

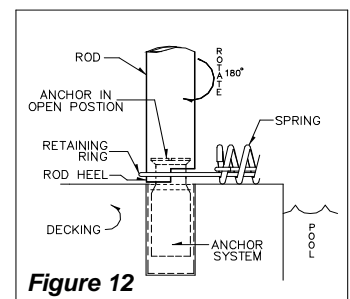
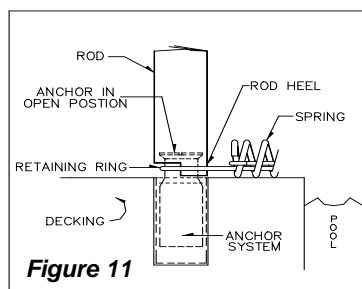

# Installation for Cable-Loc Child Safety Barrier

## PLEASE NOTE:

Any gaps will render the *installation* improper and non-safe and will void cover warranty. Cable Wall Anchor spacing greater than 18" will render the *installation* improper and non-safe and will void cover warranty. All Cable Wall Anchors must be installed or installation will be deemed non-safe and will void cover warranty.

## Cable Kit Includes:

- 7/32" Stainless steel cable with 2 vinyl caps
- Stainless steel turnbuckle 3/8" x 10 1/2" (this size has travel distance of 4")
- 4 Stainless steel U-bolts
- 1 Extra Long Brass anchor, 1 Brass anchor (for use in concrete)

**\*\*The raised wall areas of the cover must always be installed first.\*\***

## Installing Cable Wall Anchors:

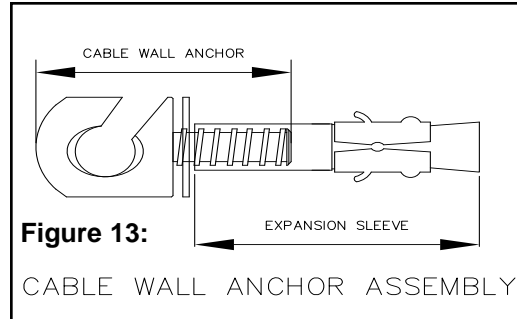

### Step 1:

Determine the first Cable Wall Anchor location and drill a 3/8" hole to a depth of 2 1/2". The hole must be drilled the entire 2 1/2" to prevent the Cable Wall Anchor assembly from sticking too far out and away from the wall.

#### Note: Tile Applications

- For tile applications two bits will be needed.
  - 1/2" glass bit
  - 3/8" standard bit as noted above
- Drill through tile using 1/2" glass bit. Once the bit breaks through the tile, switch to the 3/8" bit noted above.

### Step 2:

Remove the Cable Wall Anchor from the expansion sleeve (see figure 13). Using the wall anchor tamp tool, install the expansion sleeve anchor by tamping it to the back of the drilled hole.

### Step 3:

With the washer on the Cable Anchor, thread into the expansion sleeve all the way until contact with the wall is made.

### Step 4:

Using a screwdriver for leverage, turn the Cable Wall Anchor in a clockwise direction to "set" the wall anchor. Remember to stop with the cable slot facing upward.

### Step 5:

After installing the first Cable Wall Anchor, install all additional assemblies. Cable Wall Anchors may never be installed more than 18" apart. All inside corners must have a Cable Wall Anchor (See Figure 14). Spacing of less than 18" will be necessary when there is an inside radius to ensure that the distance from cable to wall will not exceed 2".

## Installing Cover into Raised Wall:

## PLEASE NOTE:

Cover is shipped with cable already threaded through stainless steel round rings. This is the correct location for the cable; do not install the cable onto wall anchor unless the cable is threaded through the rings. Improper cable installation can result in cover and property damage and will void the warranty.

### Step 1:

Starting at one end of raised wall, snap cable into Cable Wall Anchor. After cable is installed into all cable wall anchors, adjust cover so the raised wall treatment is centered on obstruction.

### Step 2:

Install one brass anchor into concrete deck at each end of the raised obstruction approximately 18" back from waters edge. (See Figure 14)

Note: If concrete deck is not present a concrete footing is required.

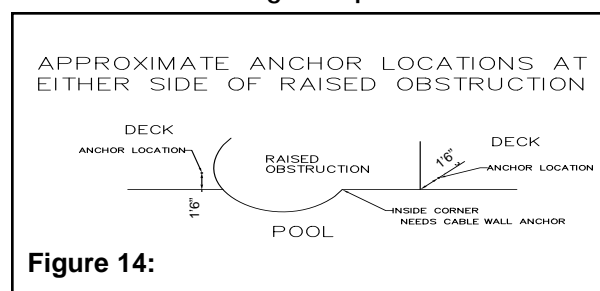

Figure 14:

**Step 3:**

Unscrew the anchor insert from the casing completely. Making sure the turnbuckle is in its most extended position, place the anchor through the turnbuckle eye and reinstall into the casing. Tighten anchor completely.

**Step 4:**

Pass the end of the cable through the unused turnbuckle eye. Make a loop with a turn back of 6" and install two U-bolts to secure the cable (See Figure 15).

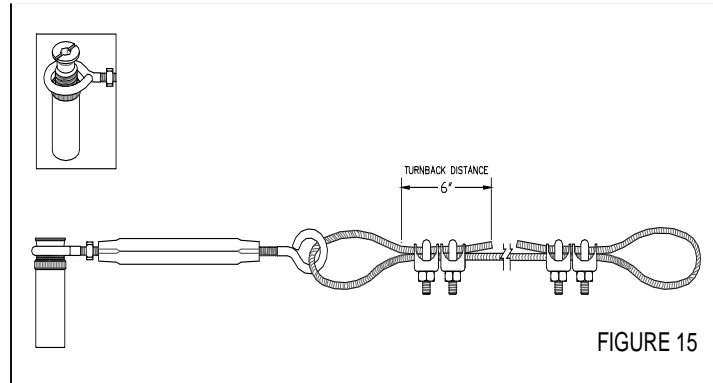

**Step 5:**

Loop the loose end of the cable around the remaining brass anchor on the opposite end of the raised obstruction, and pull by hand to tighten the cable to draw the pool cover against the obstruction.

**Step 6:**

Keeping the cable as taut as possible, install the second set of U-bolts as described in Step 4.

**Step 7:**

Rotate the turnbuckle to tighten the cable.

**Step 8:**

Proceed with the remainder of the cover installation as per the General Instructions (page 1). After completion of the entire cover installation, there should not be any gaps between the raised obstruction and the Cable-Loc Child Safety Barrier. No gap between the cover edge and the raised obstruction may be more than 3". Retighten the cable and/or trim Cable-Loc Barrier as required.

## Child Safety Barrier Installations

### LOOP-LOC's Safety Barrier Installation

In cases where raised obstructions, such as walls, at the edge of a pool may create a gap, the cover will be provided with LOOP-LOC's child safety barrier - a tough plastic extrusion sewn into the cover to fill the gap. Installation is as shown:

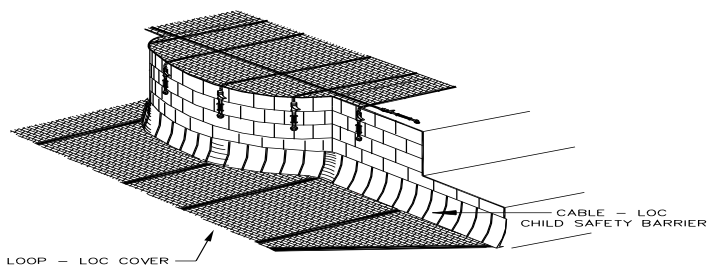

Safety Barrier may be trimmed to fit irregularities at the job site; cutting too much, however, might affect safety or damage the cover.

### LOOP-LOC's GAP-GUARD® Installation

LOOP-LOC's patented GAP-GUARD® is used to close the spaces created by varying deck levels, such as steps. GAP-GUARD® is manufactured 15' wide, but should be trimmed, after cover is fully adjusted and tightened to lie flush against rise of deck, as shown:

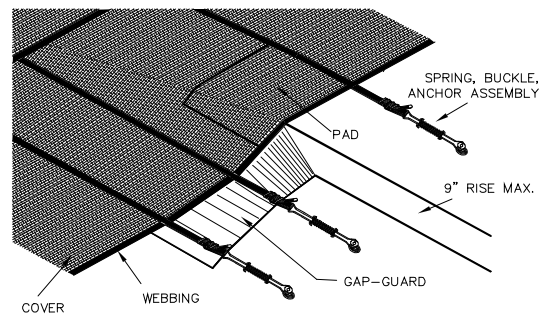

# Protect-A-Gap

Loop-Loc's Protect-A-Gap is used to close a gap 9" and greater created by varying levels. The cover should be installed, fully adjusted and tightened to lie flush on deck with the Protect-A-Gap against rise. The Protect-A-Gap material should be pulled tight against the rise, allowing the strip of anchoring holes to land against sidewall. If possible an anchor should be drilled into sidewall. If drilling into the wall is not possible use the extended strap to secure the beginning of the treatment. The first deck anchor to install should be in the first hole of the extrusion closest to the rise. Mark the anchor location using the center of the hole as a guide. Continue to mark anchor locations through the holes in the extrusion a maximum of 3' apart. When installing anchors make sure to use the Masonry collar provided between the screw and the extrusion.

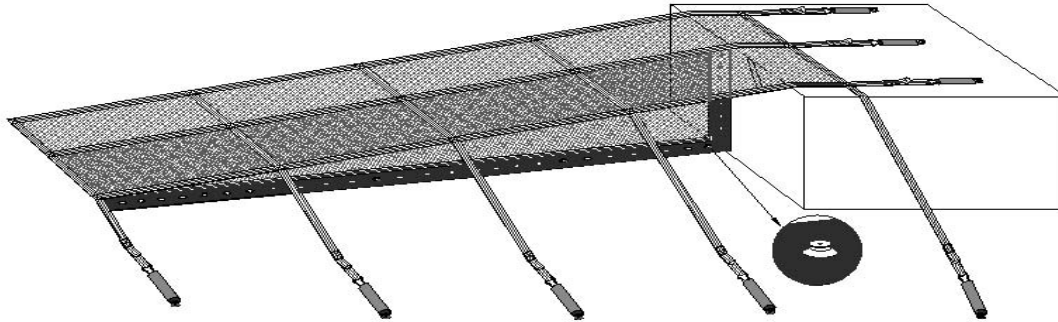

Please note: For stand-alone rises, such as spas, any extended straps behind the rise should be angled out and anchored into deck.

## Deck Elevation Changes

### Elevation Change of 8" - 15"

When the elevation change is 8" - 15", straps will be extended to reach the deck. Anchors should be installed at maximum strap length.

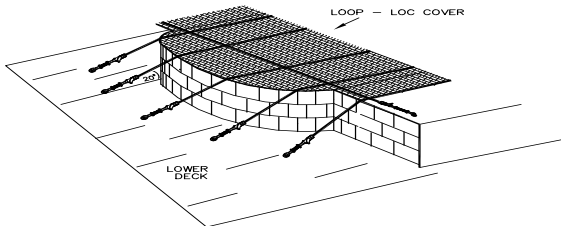

### Elevation Change of 16" or Greater

When the elevation change is 16" or greater install into side wall using brass anchors.

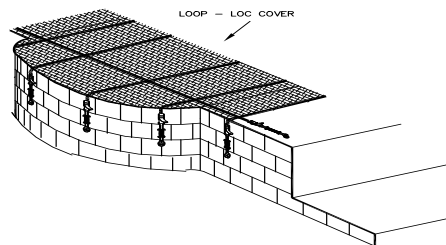

## Recommended Padding For Rough Coping/Deck, Aluminum Receptor Coping or Windy Locations.

Excessive wear due to sharp edges, wind or loose installations is not covered under warranty. All covers should be kept tight and should be adjusted when sagging appears.

If Loop-Loc water levels, tensioning requirements and padding recommendations are not followed, pools with painted aluminum or plastic concrete receptor coping may be marred. Also, if you are in a high wind area it is imperative to utilize additional padding or LOOP-LOC'S Coping Protector Caps to prevent marring. If you know these conditions exist, or have the coping types above please contact your dealer to order LOOP-LOC'S "undrcovr" padding or LOOP-LOC'S Coping Protector Caps.

Padding sharp or rough coping, deck or covers in high wind areas will help extend the life of your Loop-Loc Safety Swimming Pool Cover.

LOOP-LOC'S "Undr-Covr" padding can be purchased through your dealer.

OR

Strips of outdoor, colorfast carpeting or similar material placed under the cover around edge of pool.

Loop-Loc, LTD. 390 Motor Parkway Hauppauge, NY 11788  
1-800-LOC-LOOP In New York State 631-582-2626  
Fax #: 631-582-2636, sales@looploc.com, WWW.LOOPLOC.COM

Page 6

